

Simplex Basket Strainer

Model 72

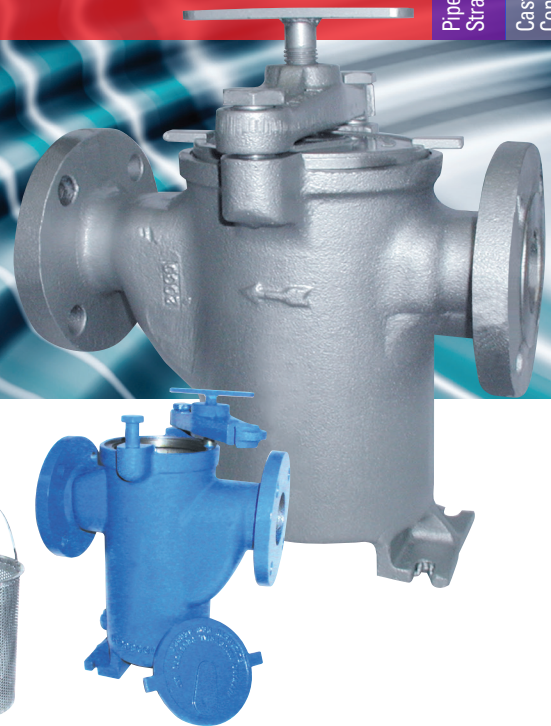

- Sizes 3/8" to 8"
- Iron, bronze, carbon steel or stainless steel
- Threaded or flanged

Features

- Quick open cover—no tools needed
- Heavy wall construction
- Large capacity baskets
- Machined basket seat
- Threaded drain
- Mounting feet for stable installation for flanged units 2" and larger
- Perforated or mesh 316 stainless steel basket
- American Bureau of Shipping (ABS) Type Approved for ship designers, builders and owners



Options

- Basket perforations from 1/32" to 1/2"
- Basket mesh from 20 to 400
- MONEL® baskets
- Viton®, PTFE encapsulated or EPDM seals
- Vent valves
- Gauge/vent taps - 1/4" NPT
- Magnetic basket inserts
- Pressure differential gauge and switch
- Flange according to DIN EN

The Eaton Model 72 has been the industry standard simplex basket strainer for more than 75 years. It is perfect for industrial and commercial applications in which the line can be temporarily shut down for strainer basket cleaning or changeout.

A reason for its popularity is the unusually large basket capacity. The free straining area with a perforated basket is a minimum of six times the cross sectional pipe area. No tools are needed to open the cover. The quick opening, swinging yoke can be disassembled and the basket removed in seconds. On sizes 4" and larger, a special cover clamp is provided to distribute

the seating pressure and to ensure positive seating of the cover.

Another feature is a threaded drain on every size strainer (fitted with a yoke quick-closer). Sizes 2" and larger are equipped with legs that bolt to the floor for rock solid installation.

Wall thicknesses are exceptionally heavy. The basket seats are precision machined to give a tight seal and prevent any material from bypassing the basket. The Eaton Model 72 simplex basket strainer is a top quality, heavy-duty unit designed to stand up to the most demanding of applications.

Model 72 simplex

Size	Material	End connection	Seals	Pressure rating*
3/8" to 3"	Iron and bronze	Threaded	Buna-N®	200 psi (13.8 bar)
1" To 3"	Carbon steel	Threaded	Buna-N	200 psi (13.8 bar)
1" To 3"	Stainless steel	Threaded	Viton	200 psi (13.8 bar)
1" To 8"	Iron	Flanged 125#	Buna-N	200 psi (13.8 bar)
1" To 8"	Bronze	Flanged 150#	Buna-N	200 psi (13.8 bar)
1" To 8"	Carbon steel	Flanged 150#	Buna-N	200 psi (13.8 bar)
1" To 8"	Stainless steel	Flanged 150#	Viton	200 psi (13.8 bar)

* @ 100 ° F (38 ° C)

MONEL® is a registered trademark of Special Metals Corporation group of Companies.
 Viton® is a registered trademark of E. I. du Pont de Nemours and company.

Model 72 Simplex Basket Strainer

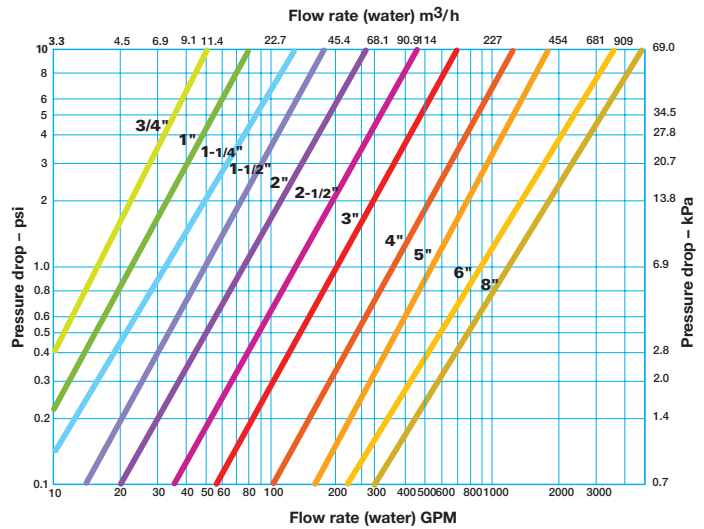
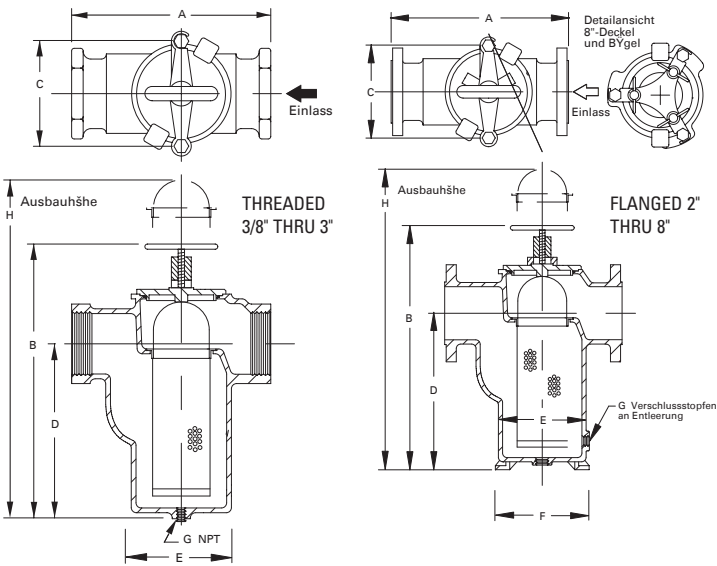

Threaded Model 72 dimensions (in/mm)

Dimensions and weights are for reference only. Contact Eaton for certified drawings.

Size	A	B	C	D	E	F	G	H	-----Net Wt (lb / kg) -----			
									Bronze	Carbon Steel	Iron	Stainless Steel
3/8	4.00 / 102	6.63 / 168	2.88 / 73	4.00 / 102	2.38 / 60	-	3/8	11 / 279	4 / 1.8	-	4 / 1.8	-
1/2	4.00 / 102	6.63 / 168	2.88 / 73	4.00 / 102	2.38 / 60	-	3/8	11 / 279	4 / 1.8	-	4 / 1.8	-
3/4	5.38 / 137	8.38 / 213	4.00 / 102	5.00 / 127	3.06 / 78	-	1/2	13 / 330	8 / 3.6	-	7 / 3.2	-
1	5.38 / 137	8.38 / 213	4.00 / 102	5.00 / 127	3.06 / 78	-	1/2	13 / 330	8 / 3.6	7 / 3.2	7 / 3.2	7 / 3.2
1-1/4	6.75 / 172	9.88 / 251	4.88 / 124	5.88 / 149	3.88 / 99	-	1/2	14 / 356	13 / 6	-	12 / 6	-
1-1/2	7.25 / 184	11.00 / 279	4.88 / 124	7.00 / 178	4.00 / 102	-	3/4	16 / 406	16 / 7	15 / 7	15 / 7	16 / 7.3
2	8.75 / 222	13.38 / 340	6.75 / 172	7.63 / 194	5.13 / 130	-	1-1/4	21 / 533	32 / 15	36 / 16	28 / 13	31 / 14
2-1/2	10.38 / 264	14.88 / 378	8.00 / 203	8.63 / 219	6.38 / 162	-	1-1/2	26 / 660	49 / 22	52 / 24	42 / 19	51 / 23
3	11.50 / 292	17.75 / 468	8.00 / 203	11.38 / 298	6.63 / 168	-	1-1/2	28 / 711	60 / 27	60 / 27	52 / 23	60 / 27

Mod. 72 Cv factors*

Size	Value	Size	Value
3/8"	15.0	2"	73
1/2"	15.0	2-1/2"	125
3/4"	15.0	3"	180
1"	22.5	4"	350
1-1/4"	31.5	6"	900
1-1/2"	46.0	8"	1400

* For water with clean, perforated basket

Flanged Model 72 dimensions (in/mm)

Dimensions and weights are for reference only. Contact Eaton for certified drawings.

Size	A	B	C	D	E	F	G	H	-----Net Wt (lb / kg) -----			
									Carbon Bronze	Steel	Stainless Iron	Steel
1	7.63 / 194	8.38 / 213	4.00 / 102	5.00 / 127	-	-	1/2	13.00 / 330	16 / 7	9 / 4	9 / 4	9 / 4
1 1/2	10.25 / 260	11.00 / 279	4.88 / 124	7.00 / 178	-	-	3/4	16.00 / 406	30 / 14	17 / 7.7	17 / 7.7	17 / 7.7
2	10.50 / 268	13.75 / 349	6.75 / 172	7.63 / 194	5.13 / 130	6.25 / 159	3/8	20.00 / 508	49 / 22.3	36 / 16	36.5 / 17	36 / 16
2 1/2	11.63 / 295	15.63 / 397	8.00 / 203	8.88 / 226	6.38 / 162	7.63 / 194	3/8	23.00 / 584	64 / 29.1	63 / 27	54 / 25	63 / 29
3	13.13 / 334	18.00 / 457	8.00 / 203	10.63 / 270	6.50 / 165	8.00 / 203	3/8	27.00 / 686	85 / 38.6	-	76 / 35	-
3	13.13 / 334	18.75 / 476	7.94 / 202	12.00 / 305	6.50 / 165	8.00 / 203	1/2	27.00 / 686	-	86 / 39	-	86 / 39
4	16.75 / 425	19.88 / 505	10.75 / 273	10.75 / 273	9.63 / 245	11.38 / 289	1/2	30.00 / 762	140 / 63.6	-	125 / 55	-
4	17.25 / 438	19.88 / 505	10.69 / 272	10.69 / 272	9.25 / 235	11.38 / 289	1/2	30.00 / 762	-	130 / 59	-	130 / 59
5	18.13 / 461	25.13 / 638	10.75 / 273	15.25 / 387	10.00 / 254	11.38 / 289	1/2	41.00 / 1,041	182 / 82.7	-	170 / 775	-
6	19.63 / 499	28.50 / 724	10.69 / 272	18.38 / 467	10.00 / 254	11.38 / 289	1/2	46.00 / 1,168	270 / 122.7	235 / 107	200 / 91	235 / 107
8	27.00 / 686	40.50 / 1,029	-	27.00 / 686	13.75 / 349	17.50 / 445	1/2	60.00 / 1,524	600 / 272.7	550 / 250	500 / 227	550 / 250



Brisbane, Australia
 www.monarchindustrial.com.au
 www.monarchasiapacific.com.au