

# Model 50



- Sizes 5", 6", 8"
- Iron, bronze, carbon steel or stainless steel
- Flanged



## Features

- Continuous flow, no shutdown for basket cleaning
- Rugged tapered plug design
- Lift jack prevents galling of the plug
- Quick open cover—no tools needed
- Large capacity baskets
- Threaded drain
- Machined basket seat
- Perforated or mesh 316 stainless steel basket

## Options

- Ductile iron construction
- Basket perforations from 1/32" to 1/2"
- Basket mesh from 20 to 400
- MONEL® baskets
- Vent valves
- Drain valves
- Gauge/vent taps - 1/4" NPT
- Magnetic basket inserts
- Pressure differential gauge and switch connections
- Viton®, PTFE encapsulated or EPDM seals
- Cast iron and stainless steel diverter plug



## Trouble-free design, easy operation

The Eaton Model 50 plug type duplex strainer's design is simple and economical. This high-quality strainer is, in fact, a pressure rated plug valve with integral straining baskets.

To switch the flow from one basket to the other, the operating handle moves through a 90-degree arc. Because of the unique port design in the diverter plug, it is impossible for this operation to stop the flow. The entire switching operation takes fewer than 30 seconds, no tools required. Positioning the plug each time in exactly the right spot happens automatically by integral stops.

Before operating the handle, a specially designed, manual lifting jack built into the strainer, lifts the diverter plug

off its seat. After the switching operation, the jack easily reseats the plug, even under high pressures. Because a built-in stop limits the distance the diverter plug rises, it minimizes the possibility of material bypassing the plug while rotated to divert flow. It also prevents debris from building up under the plug and making it difficult to reseal.

## Other features

- A quick, easy to open, swing-away yoke design cover goes back on just as fast as it came off
- Standard NPT drain taps simplify the draining of the basket chamber
- All sizes come with mounting legs for bolting the strainer to the floor for a rock solid installation

# Model 50 Plug Type Duplex Basket Strainer

## Selection chart

Size	Body material	Plug material	End connections	Seals
5", 6", 8"	Iron	Bronze	Flanged 125#	Buna-N®
5", 6", 8"	Bronze	Bronze	Flanged 150#	Buna-N
6", 8"	Carbon steel	Bronze	Flanged 150#	Buna-N
6", 8"	Stainless steel	Stainless steel	Flanged 150#	Viton

DIN flanges available on 6" only

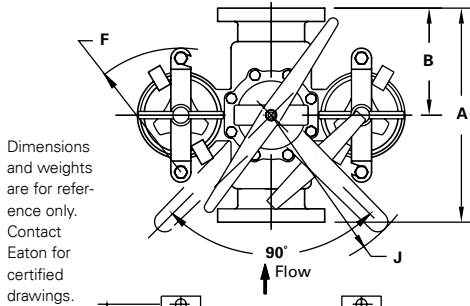

Dimensions and weights are for reference only. Contact Eaton for certified drawings.

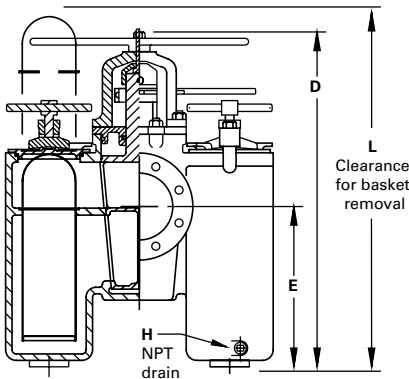
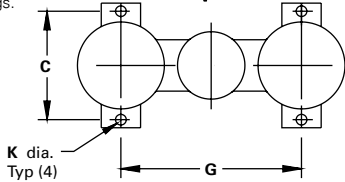

## Rating

Size	Rating*
5"	200 psi (13.8 bar)
6"	200 psi (13.8 bar)
8"	150 psi (10.3 bar)

\* @ 100 °F (38 °C)

## Cv factors\*

Size	Value
5"	300
6"	420
8"	900

\* For water with clean, perforated basket

Partial cutaway of Model 50 duplex strainer clearly illustrates all major parts—and gives a clear indication of the simplicity of design and ease of maintenance.

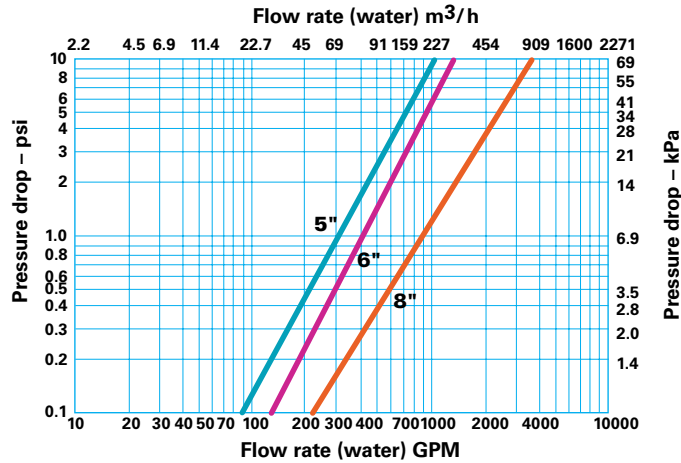
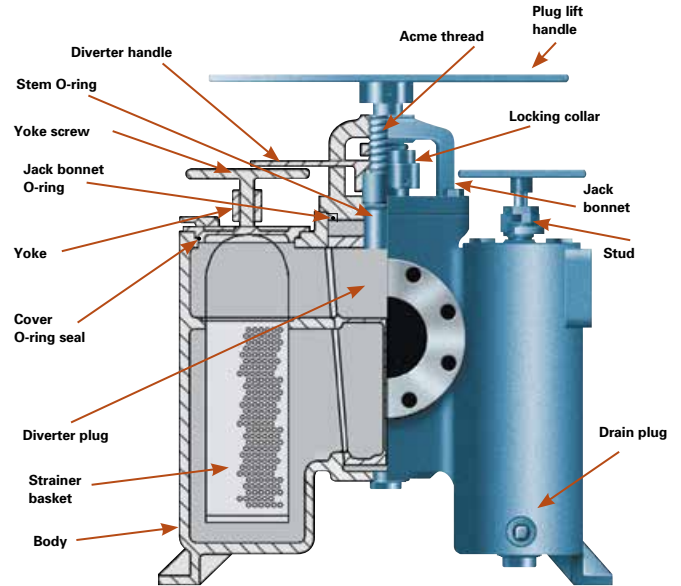

## Dimensions (in/mm)

Pipe size	A	B	C	D	E	F	G	H	J	K	L	Weight (lb/kg)			
												Cast iron	Bronze	Carbon steel	Stainless steel
5	18.38	9.00	9.75	33.25	14.75	10.25	17.19	3/8	19.75	0.56	41.00	403	412	-	-
	467	229	248	845	375	260	437	-	502	14	1041	183	187	-	-
6	22.00	12.88	12.50	36.25	19.50	11.75	20.75	3/8	19.75	0.63	42.00	500	583	580	615
	559	327	318	921	495	298	527	-	502	16	1067	227	264	263	279
8	25.00	14.00	17.00	50.63	23.06	-	30.75	1/2	28.00	0.94	56.00	1500	1800	1610	1670
	635	356	432	1286	586	-	781	-	711	24	56	682	818	732	759

US  
EF-SSEA-12  
6-2014



www.monarchindustrial.com.au



Powering Business Worldwide

