

Read all the following information and instructions prior to installing and operating the equipment.
Failure to comply with these instructions could result in bodily injury or property damage.



TABLE OF CONTENTS

Introduction	1
Receiving, Handling, and Inspection	2
Installation.....	2
Start Up	3
Operation	3
Switching Flow.....	3
Basket Removal and Cleaning	4
Basket Replacement	4
Shut Down	4
Recommended Spare Parts.....	5

INTRODUCTION

The Eaton Model 53BTX duplex strainer easily installs in pipelines to remove sediment and debris from fluids. Fluid flows uninterrupted while the basket is removed for cleaning. These strainers are designed for pressure or suction applications.

Straining on the Model 53BTX is accomplished by directing the fluid through sized openings in the basket. Once sediment and debris is collected in the basket, the fluid flow is directed by manually turning the handle over to the other basket for continuous operation. At this time the debris filled basket can be removed for cleaning.

For additional information regarding Model 53BTX Duplex Strainers visit our website at www.eaton.com/filtration



Brisbane, Australia
www.monarchindustrial.com.au
www.monarchasiapacific.com.au

RECEIVING, HANDLING, AND INSPECTION

1. Unpack the strainer and inspect for damage occurring during transit. Report damage to the carrier. If the strainer is not installed immediately, see "Storage" instructions.
2. Remove any preservatives with solvent-dampened cloths. Exercise care when using solvent and follow solvent manufacturer's instructions.
3. Verify that the rating of the strainer is greater than or equal to the maximum pressure and temperature of the installation.
4. Open each basket well cover by turning the eye nut counterclockwise to end of studs. Lift cover up by the tabs until cover is free of basket well and rotate cover counterclockwise, clearing the basket well.
5. Remove all flange or nozzle protectors. Check the inside of the body for any foreign or loose material that could be carried downstream when fluid is introduced into the strainer. Install the strainer baskets. Reset the covers by reversing procedure above. To tighten, turn eye nuts clockwise until the cover is seated and secured at the top of the basket well.
6. The cover to basket handle contact holds the baskets in place. If the basket handle is not in contact with the cover, bend the handle to a higher position to insure greater compressions when cover is seated.

STORAGE

Replace protective wrap, flange protectors etc. that may have been removed during receiving, handling and inspection. Store the strainer in a clean, dry environment.

INSTALLATION



CAUTION: Before installation, review the application and chemical compatibility of the process fluid to all the materials of construction and components of the strainer.

INSTALLATION (CONTINUED)

1. Remove protective wraps, caps, plugs etc. before installing the strainer. Be sure to inspect cover gasket or O-ring for possible damage and replace as required. Position the strainer in the pipeline so that the fluid enters the connection marked "IN" or "INLET."



CAUTION: To lift flanged duplex strainers, put slings under the inlet and outlet connections and secure above strainer. To lift duplex strainers with threaded connections, put slings under the center body section and secure above strainer.

2. Be sure sufficient clearance is provided for easy opening of the cover and removal of the basket. Refer to the Sales Drawing for removal clearances. Support the strainer to a firm foundation by using the footpads. Refer to sales drawing for footpad layout.
3. Connect the strainer to the pipeline. On flanged strainers, be sure to use the same type of flange faces. **Do not bolt a raised face flange to a flat face flange.** Be sure flange gaskets are in place and fasteners are tight.
4. On threaded strainers with other line connections, use standard piping practice when installing the strainer.



CAUTION: Duplex strainers are not designed to be anchor supports in the piping line. Be sure to properly support process piping on both sides of the strainer. Use care to prevent piping forces and movements from acting on the strainer connections. Damage may occur to the strainer if improperly connected.



Brisbane, Australia
www.monarchindustrial.com.au
www.monarchasiapacific.com.au

INSTALLATION (CONTINUED)

Eaton recommends that basket well drain plugs be removed and pressure equalizer valves with a drain valve be installed (standard on 4" size) see Figure 1.



Figure 1

Eaton also recommends replacing each cover plug with a vent valve and piping to a safe area. See Figure 2.



Figure 2

Pressure gauges near the strainer inlet and outlet are required to determine differential pressure across the strainer and cleaning frequency. Pressure gauges are essential for the safe operation of the strainer.



CAUTION: To protect the operator during draining and venting, the fluid must be piped to a safe area. This requirement is for all fluids and water with temperatures above 120° F.

The operator should wear appropriate protective equipment (goggles, gloves, vests, clothing etc.) consistent with the process fluid for strainer operation and servicing.

START UP

1. Open cover vent valves and cartridge vent. Close pressure equalizer valves and drain valve. Rotate the handle 90° clockwise, so that the handle is over the strainer inlet.
2. **Slowly** allow fluid to enter the strainer. First, **slowly** open the downstream valve nearest to strainer outlet. Then **slowly** open the upstream valve nearest to the strainer inlet.
3. Close cover vent valves and cartridge vent when air is expelled. Rotate the handle 90° counterclockwise over the right side basket well. See Figure 3.

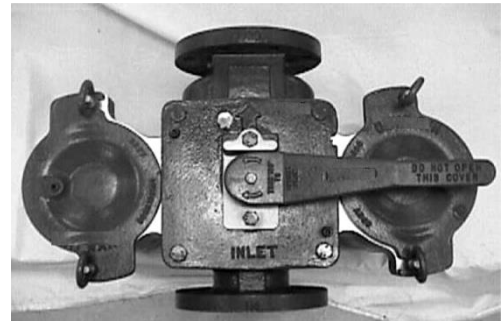

Figure 3

OPERATION

The strainer handle's position indicates which basket well is in operation. The handle in the 3 o'clock position over the cover indicates the right basket operation. This **prevents** access to the basket underneath the handle. See Figure 3. The handle in the 9 o'clock position indicates the left basket operation **Note:** Above references are with the strainer inlet in the 6 o'clock position.

SWITCHING FLOW

Open both pressure equalizer valve to insure that both basket wells are pressurized and rotate the strainer handle 180° (traveling over the strainer inlet) until the handle is over the opposite basket cover from where the handle started. Close both pressure equalizer valves.

BASKET REMOVAL AND CLEANING

A differential pressure increase of **5 psi** across the strainer indicates that the basket in operation is full of debris and needs to be removed and cleaned.



CAUTION: To prevent damage to the baskets, **DO NOT** permit the differential pressure across the strainer to exceed 20 psi.

1. Transfer flow from the basket well in operation to the opposite basket well. Refer to **Switching Flow**. Open the drain valve.
2. To service the basket well, slowly open the cover vent and drain or pressure equalizer valve (if installed). This relieves the pressure and drains the fluid in that basket well.
3. When pressure is relieved and fluid drained, open the basket well cover by turning the eye nuts counterclockwise to end of studs. Lift cover up by the tabs until cover is free of basket well and rotate cover counterclockwise, clearing the basket well.
4. Remove the debris-laden basket. Invert the basket and wash out the debris. Direct a stream of air or water from the exterior of the basket to the interior. Note: Do not permit the basket debris to dry, as it would be difficult to remove and clean the basket. Inspect basket at each cleaning for holes or tears. Replace as needed with genuine Eaton strainer baskets.

BASKET REPLACEMENT

1. Place the cleaned or new basket into the basket well. Be sure basket handle is sufficiently high to be compressed by the cover. Refer to **Receiving, Handling, and Inspection**. Inspect cover O-ring and sealing surface. Clean sealing surface and replace O-ring as necessary. Reseat the cover. Refer to **Receiving, Handling and Inspection**.
2. Close drain valve and open pressure equalizer and cover vent valves of basket well just serviced. Open the pressure-equalizing valve of the basket well in operation filling the serviced basket well with fluid. Then close cover vent valve when air is expelled. Next, close both pressure equalizing valves.

SHUT DOWN

1. Slowly close the pipeline valves upstream and downstream from the duplex strainer. Make sure these valves are tightly closed.
2. To relieve fluid pressure in the strainer, first open the drain valve. Then slowly open the pressure equalizer and cover vent valves.
3. Proceed to clean and inspect each basket. Inspect the strainer to insure there is no standing fluid.

RECOMMENDED SPARE PARTS

- 2 Strainer Baskets
- 2 Cover O-rings
- 4 Stem O-rings **
- 2 Cartridge O-rings**
- 4 Seals**
- 4 Seats **

** Only supplied in a “#53 sealing kit”

When ordering spare parts, be sure to specify all nameplate data as well as description and quantity of parts.

Always use genuine Eaton replacement parts for guaranteed fit and performance.

Visit our web site, filtration.eaton.com for information about the different types of Eaton Duplex Basket Strainers.



Brisbane, Australia
www.monarchindustrial.com.au
www.monarchasiapacific.com.au

Top View

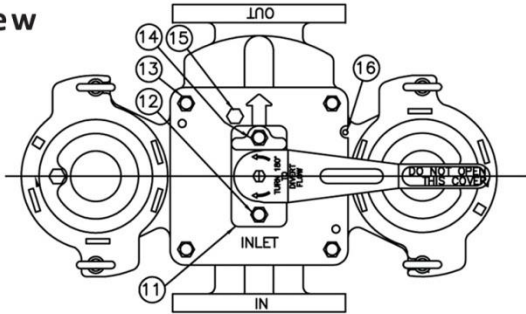

Side View

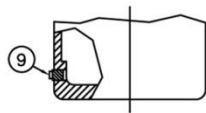
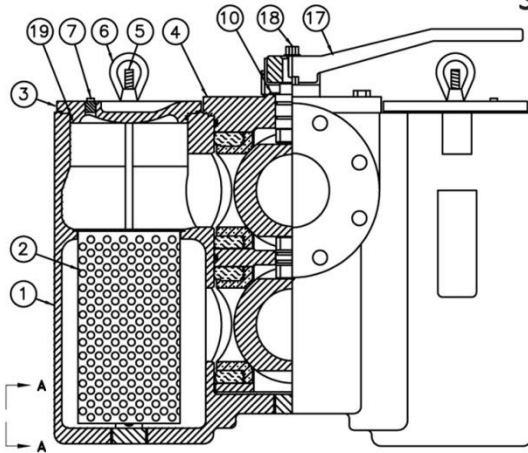

VIEW A-A

Diverter Cartridge Assembly

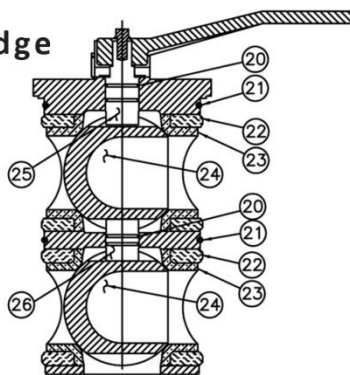

VIEW B-B

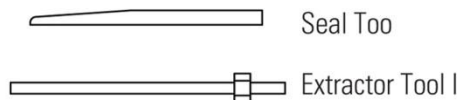

PARTS LIST FOR EATON MODEL 53BTX

Item Description

1. Duplex Strainer Body
2. Strainer Basket (2) *
3. Basket Cover (2)
4. Cartridge
5. Stud (4)
6. Eye Nut (4)
7. Pipe Plug (2)
9. Pipe Plug (2)
10. Washer
11. Stem Retainer
12. Cap Screw
13. Cap Screw (4)
14. Cap Screw
15. Vent Valve
16. Pin
17. Handle
18. Cap Screw
19. O-Ring, Cover
20. O-Ring, Stem (4) *
21. O-Ring, Cartridge (2) *
22. Seal (4) *
23. Seat (4) *
24. Ball (2)
25. Stem, Top
26. Stem, Middle

* Recommended Spare Parts List

Item	Description
2	Strainer Basket (2)
19	O-Ring, Cover (2)
20**	O-Ring, Stem (4)
21**	O-Ring, Cartridge (2)
22**	Seal (4)
23**	Seat (4)

** Only supplied in a "#53 sealing kit"

Diverter Cartridge Maintenance

The Diverter Cartridge assembly is maintenance free. No initial or operational servicing is required. In the event that the cartridge O-rings, stem O-rings, seats, or seals need replacement, Sealing Kits are available for strainer sizes: ¾" – 1", 1¼" – 1½", 2" – 2½", 3" and 4."