

## Temporary Cone Strainer (Example sizes only)

SIZE	A				B	C				F'
	150/300#	600#	900#	1500#		100%	150%	200%	300%	
¾ (20)	2½ (54)	2½ (64)	2½ (67)	2½ (67)	¾ (16)	1½ (29)	1 2/3 (43)	2¼ (57)	3½ (86)	¾ (3)
1 (25)	2½ (64)	2¾ (70)	3 (76)	3 (76)	¾ (19)	1½ (41)	2 ½ (64)	3 1/3 (84)	5 (127)	¾ (3)
1½ (40)	3¼ (83)	3½ (92)	3¾ (95)	3¾ (95)	1¼ (32)	2½ (56)	3 ¾ (86)	4½ (114)	6½ (171)	¾ (3)
2 (50)	4 (102)	4¼ (108)	5½ (140)	5½ (140)	1¼ (44)	3 (76)	4 ½ (114)	6 (152)	9½ (232)	¾ (3)
2½ (65)	4¾ (121)	5 (127)	6¾ (162)	6¾ (162)	2¼ (57)	3½ (81)	5 (127)	6¾ (170)	10½ (257)	¾ (3)
3 (80)	5¼ (133)	5½ (146)	6½ (165)	6½ (171)	2¼ (70)	4 (102)	6¼ (159)	8½ (216)	12¼ (324)	¾ (3)
4 (100)	6¾ (171)	7½ (191)	8 (203)	8½ (206)	3¼ (95)	5½ (130)	7½ (200)	10½ (270)	17 (432)	¾ (3)
5 (125)	7¾ (194)	9½ (238)	9¾ (244)	9¾ (251)	4¾ (117)	6½ (165)	10½ (257)	14 (356)	21 (533)	¾ (3)
6 (150)	8¾ (219)	10¾ (263)	11¼ (286)	11 (279)	5¾ (137)	8½ (207)	13 (330)	17 (432)	26 (660)	¾ (3)
8 (200)	10¾ (276)	12½ (318)	14 (356)	13¾ (349)	7¾ (187)	10½ (259)	16 (406)	22 (559)	33 (838)	¾ (3)
10 (250)	13¼ (337)	15¾ (397)	17 (432)	17 (432)	9¾ (238)	13 (330)	20 (508)	27 (686)	40 (1016)	¾ (3)
12 (300)	16 (406)	17¾ (454)	19½ (495)	20¾ (517)	11 (279)	16 (406)	24 (610)	33 (838)	49 (1245)	¾ (3)
14 (350)	17¾ (441)	19 (483)	20¾ (517)	22¾ (575)	12¼ (311)	17 (432)	27 (686)	36 (914)	54 (1372)	¾ (3)
16 (400)	20¾ (511)	21¾ (555)	22½ (572)	25¾ (638)	14 (356)	20 (508)	31 (787)	41 (1041)	62 (1575)	¾ (3)
18 (450)	21¼ (540)	23¾ (603)	25 (635)	27¾ (702)	15¾ (400)	23 (584)	35 (889)	47 (1194)	71 (1803)	¾ (3)
20 (500)	23½ (597)	26¾ (676)	27¾ (695)	29¾ (753)	17¾ (445)	25 (635)	39 (991)	53 (1346)	79 (2007)	¾ (3)
24 (600)	27¾ (708)	30¾ (784)	32¾ (835)	35¾ (899)	21¼ (540)	30 (762)	47 (1194)	63 (1600)	95 (2413)	¾ (3)

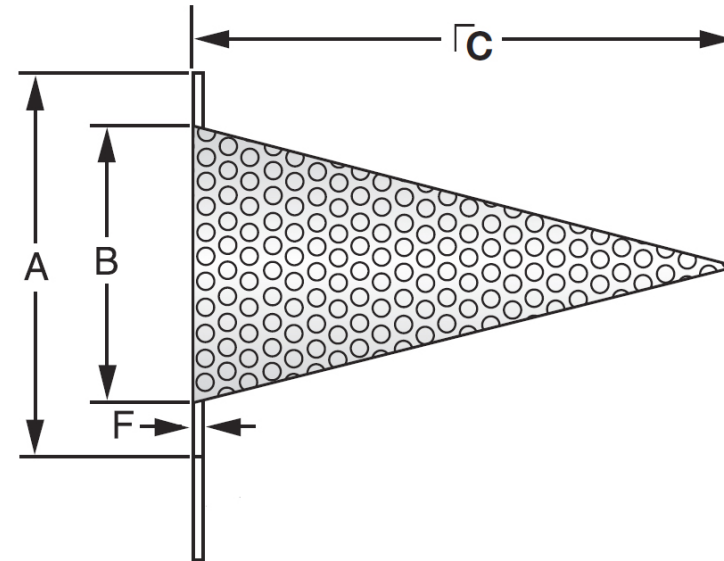

Sizing based on using perforated metal with 2mm holes x 3mm pitch with an open area of 40%.

Open Area percentage will change with alternate perf and/or mesh.  
Custom sizes are available to process application.

Monarch Asia Pacific Pty Ltd  
www.monarchindustrial.com.au



Description

Temporary Cone Strainer (Example sizes)

Drawn By

Job Ref

Date

Not to Scale

Dwg No.

MTC

Rev