

**HAYWARD FLOW CONTROL
WCV SERIES WAFER CHECK VALVE
INSTALLATION, OPERATION AND MAINTENANCE INSTRUCTIONS**



PLEASE READ THE FOLLOWING INFORMATION PRIOR TO INSTALLING AND USING HAYWARD WCV SERIES WAFER CHECK VALVES. FAILURE TO FOLLOW THESE INSTRUCTIONS MAY RESULT IN PRODUCT DAMAGE, PROPERTY DAMAGE, PERSONAL INJURY, OR EVEN DEATH.

1. Hayward Flow Control (Hayward), a division of Hayward Industries, guarantees its products against defective material and workmanship only. Hayward assumes no responsibility for property damage or personal injury resulting from improper installation, misapplication, or abuse of any product.
2. Hayward assumes no responsibility for property damage or personal injury resulting from chemical incompatibility between its products and the process fluids to which they are exposed. Determining whether a particular PVC, CPVC, or PP product is suitable for an application is the responsibility of the user. Chemical compatibility charts provided in Hayward literature are based on ambient temperatures of 70°F and are for reference only.
3. Hayward products are designed for use with non-compressible liquids.

WARNING

Hayward PVC and CPVC products should NEVER be used or tested with compressible fluids such as compressed air or nitrogen. Use of PVC and CPVC products in compressible fluid applications may result in product damage, property damage, personal injury, or even death.

WARNING

The Series WCV Wafer Check Valve is intended for use in liquid service only. Do not attempt to use this valve for checking air or gases. Use of this product in air or gas service may result in product damage, property damage, personal injury, or even death.

4. The maximum recommended fluid velocity through any Hayward product is eight feet per second (8 ft/s). Higher fluid velocity can result in damage due to the water hammer effect.
5. Piping systems must be designed and supported to prevent excess mechanical loading on Hayward products due to system misalignment, weight, shock, vibration, and the effects of thermal expansion and contraction.
6. The effect of temperature on plastic piping systems must be considered when the systems are initially designed. The pressure rating of plastic systems must be reduced with increasing temperature. Maximum operating pressure is dependent upon material selection as well as operating temperature. Before installing any Hayward product, consult Hayward product literature for pressure vs. temperature curves to determine any operating pressure or temperature limitations.
7. PVC and CPVC plastic products become brittle below 40°F. Use caution in their installation and operation below this temperature.

WARNING

Hayward PVC and CPVC products should not be used in services with operating temperature below 34°F.

8. Due to differential thermal expansion rates between metal and plastic, transmittal of pipe vibration and pipe loading forces, **DIRECT INSTALLATION OF PLASTIC VALVES INTO METAL PIPING SYSTEMS IS NOT RECOMMENDED.** Wherever installation of plastic valves into metal piping systems is necessary, it is recommended that at least 10 pipe diameters in length of plastic pipe be installed upstream and downstream of the plastic valve to compensate for the factors mentioned above.
9. Published operating requirements are based on testing of new valves using clean water at 70°F. Valve performance is affected by many factors including fluid chemistry, viscosity, specific gravity, flow rate, and temperature. These should be considered when sizing Hayward products.
10. Systems should always be depressurized and drained prior to installing or maintaining any Hayward product.

WARNING

Failure to depressurize and drain system prior to installing or maintaining valve may result in product damage, property damage, personal injury, or even death.

1.0 INSTALLATION:

1.1 Transporting the Valve:

- 1.1.1 Valve should be stored inside factory packaging until product is ready to be installed. Packaged valve should be stored indoors, at room temperature, and out of direct sunlight. Avoid storing packaged valve in location where packaging may become wet. Valve should be moved as close to installation site as possible prior to removing from packaging. After removing valve from carton, care must be taken not to damage valve or to allow debris to enter valve.

1.2 Installing the Valve into a System:

WARNING

System must be depressurized and drained prior to installing valve or performing maintenance. Failure to depressurize and drain system prior to installing or maintaining valve may result in product damage, property damage, personal injury, or even death.

CAUTION

Hayward WCV-Series wafer check valves must be installed with flow arrows pointing in the direction of flow, and with the top of the valve oriented to the top of the piping system.

Do not install valve directly to pump outlet. Allow a length of at least 5 pipe diameters between pump outlet and valve.

Do not install valve directly after a reducer / expansion fitting. Install at least 5 pipe diameters from an expansion or reducing fitting.

Pipe must be supported upstream and downstream of the valve. Sound piping system design principles should be applied when installing this valve.

Do not install valve directly into a metal system (see pg. 2). Wherever installation of plastic valves into metal piping systems is necessary, it is recommended that at least 10 pipe diameters in length of plastic pipe be installed upstream and downstream of the plastic valve.

When lifting valve, always lift by valve body. Never lift by retainer or disc. Due to the weight of the 10" and 12" sizes, a strap may be placed through the handle on the valve to aid in lifting the valve.

- 1.2.1 Remove valve from packaging.
1.2.1.1 Verify that product is defect free and meets specifications.
- 1.2.2 Wafer check valve should be installed between ANSI 150 flanges.
1.2.2.1 Do not install valve directly to pump outlet.
1.2.2.2 Do not install valve directly adjacent to elbow.
1.2.2.3 Valve must have a minimum of 5 pipe diameters upstream and downstream from any pumps or direction changing fittings.
- 1.2.3 Flanges must be aligned and square to valve.
- 1.2.4 Center valve to flange
1.2.4.1 Size 2" – 3" valves should be centered via the outer diameter of the valve body
1.2.4.2 Size 4" – 8" valves are equipped with four bolt holes (two upper and two lower) to aid with valve centering and installation
1.2.4.3 Size 10" – 12" valves are equipped with 4 bolt holes, 2 of which pass through the upper handle of the product
- 1.2.5 Installations in systems with vertical pipe orientation:
1.2.5.1 Valve must be installed so that "TOP SIDE" indication on valve body faces upwards.
1.2.5.2 System flow must be upwards. Flow arrow on body should be oriented in same direction as system flow.
- 1.2.6 Installations in systems with horizontal pipe orientation:
1.2.6.1 Valve must be installed so that "TOP SIDE" indication on valve is between top two flange bolts.
1.2.6.2 Valve must be installed so that arrows on valve body indicate system flow direction.
- 1.2.7 Install bolts hand tight. See Table 1 for required bolt diameter.
- 1.2.8 Using a torque wrench, tighten bolts in an alternating sequence. See Figure 1. Refer to Table 1 for recommended bolt torque.
- 1.2.9 Slowly purge air from system and pressurize.
1.2.9.1 Look for leaks around valve and check for proper valve operation.
1.2.9.2 If any leaks are present, or valve does not perform properly, refer to troubleshooting guide. Depressurize and drain system prior to performing any maintenance.

WARNING

System must be depressurized and drained prior to installing valve or performing maintenance. Failure to depressurize and drain system prior to installing or maintaining valve may result in product damage, property damage, personal injury, or even death.

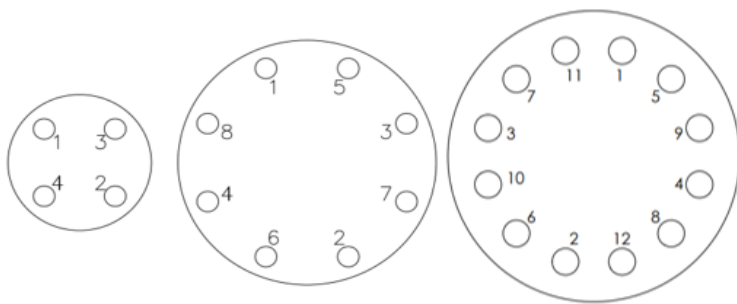

Fig. 1: Flange Bolt Torque Sequence

Flange Size	Bolt Dia. (in.)	Torque (ft-lbs)
2	5/8	15 – 25
2-1/2	5/8	20 – 25
3	5/8	20 – 25
4	5/8	20 – 25
6	3/4	30 – 40
8	3/4	30 – 40
10	7/8	54 – 64
12	7/8	85 – 95

NOTE: Use well lubricated metal bolts and nuts.

Table 1: Recommended Flange Bolt Torque

2.0 OPERATION:

- 2.1.1 WCV-Series wafer check valves are designed to prevent reverse flow automatically when system is shut down. Valve will open when upstream pressure exceeds downstream pressure.
- 2.1.2 Periodically check valve for leaks or external damage.
- 2.1.3 Periodically check flange bolts for correct torque. (NOTE: Retightening of nuts may be necessary after initial system start-up.)

3.0 MAINTENANCE:

WARNING

System must be depressurized and drained prior to installing valve or performing maintenance. Failure to depressurize and drain system prior to installing or maintaining valve may result in product damage, property damage, personal injury, or even death.

3.1 Replacing Valve O-rings:

- 3.1.1 WCV-Series wafer check valves are assembled with four o-rings. Two o-rings are used as flange face seals. One o-ring is installed on the disc, and the final o-ring is installed between the retainer and the body. (See Figure 3.)
- 3.1.2 To replace the face seals:
 - 3.1.2.1 Using a plastic pick, carefully remove the old seals. NOTE: Be very careful not to damage the o-ring grooves or valve body.
 - 3.1.2.2 Clean o-ring grooves with a soft brush or cloth.
 - 3.1.2.3 Install new o-rings by gently pressing o-ring into groove until o-ring is fully seated.
- 3.1.3 To replace the disc o-ring:
 - 3.1.3.1 Separate the retainer from the body by gently pulling the retainer away from the body while holding the body firmly. NOTE: Friction exists between the retainer and body. Retainer removal will be eased by rocking retainer in relation to body.
 - 3.1.3.2 Note orientation of disc in relation to body. Remove disc from body.
 - 3.1.3.3 Using a plastic pick, carefully remove the old seal. NOTE: Be very careful not to damage the o-ring groove.
 - 3.1.3.4 Clean o-ring grooves with a soft brush or cloth.
 - 3.1.3.5 Install new o-ring by inserting o-ring into groove on large end of disc, then gently stretching o-ring over small end of disc and into groove.
 - 3.1.3.6 Re-install disc into body. NOTE: Make certain that disc o-ring is in contact with seal surface in body.
 - 3.1.3.7 Inspect retainer o-ring and replace if necessary. Install o-ring on shoulder of retainer.
 - 3.1.3.8 Re-install retainer by gently and evenly pressing retainer into body. NOTE: Retainer must be kept square to body during retainer installation to prevent retainer o-ring from becoming damaged.
- 3.1.4 To replace the retainer / main body o-ring:
 - 3.1.4.1 Separate the retainer from the body by gently pulling the retainer away from the body while holding the body firmly. NOTE: Friction exists between the retainer and body. Retainer removal will be eased by rocking retainer in relation to body.
 - 3.1.4.2 Remove old seal from retainer.
 - 3.1.4.3 Clean seal area on retainer and in body bore with a soft brush or cloth.
 - 3.1.4.4 Install new o-ring onto shoulder of retainer.
 - 3.1.4.5 Re-install retainer by gently and evenly pressing retainer into body. NOTE: Retainer must be kept square to body during retainer installation to prevent retainer o-ring from becoming damaged.

3.2 Installing a Spring:

- 3.2.1 WCV-Series wafer check valves are available with or without spring assisted closing.
- 3.2.2 To install a spring in units originally not equipped with a spring:
 - 3.2.2.1 Separate the retainer from the body by gently pulling the retainer away from the body while holding the body firmly. NOTE: Friction exists between the retainer and body. Retainer removal will be eased by rocking retainer in relation to body.
 - 3.2.2.2 Note orientation of disc in relation to body. Remove disc from body.
 - 3.2.2.3 Remove end cap from disc shaft.
 - 3.2.2.4 Install spring over disc shaft. The shorter leg of the spring should point away from the disc, and the hook on the longer leg of the spring should wrap around the rib on disc. (See Fig. 2A.)
 - 3.2.2.5 Install end cap over end of disc shaft. (End cap retains spring and prevents it from slipping off disc during assembly and operation. End cap is used on 2" – 8" sizes only.) NOTE: 10" & 12" sizes do not require an end cap.

- 3.2.2.6 Re-install disc into body. NOTE: Spring will engage a spring retaining groove in the shaft pocket of the body as disc is installed. Be certain to insert disc shaft fully into body. (See Fig. 2B.)
- 3.2.2.7 Inspect retainer / main body o-ring and replace if necessary.
- 3.2.2.8 Re-install retainer by gently and evenly pressing retainer into body. NOTE: Retainer must be kept square to body during retainer installation to prevent retainer o-ring from becoming damaged.

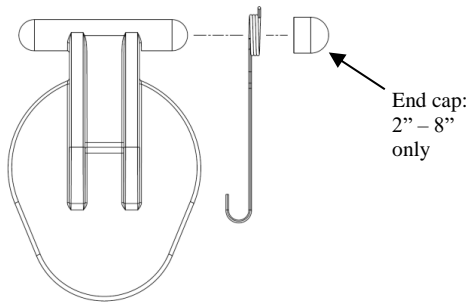

Fig. 2A: Disc, spring, and end cap (unassembled) 2" – 8"

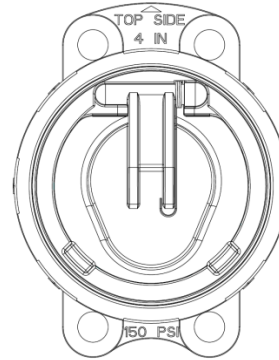

Fig. 2B: Disc, spring, and end cap inside body 2" – 8"

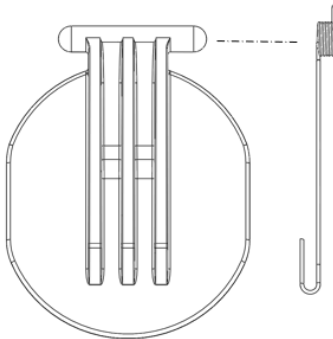

Fig. 2C: 10" Disc and spring (unassembled) 10" & 12"

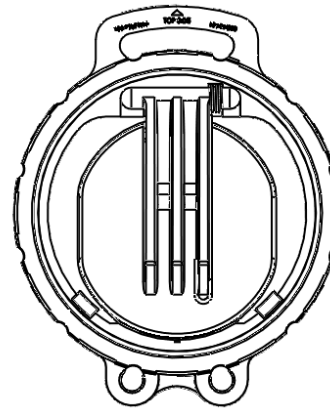

Fig. 2D: 10" Disc and spring inside body 10" & 12"

4.0 TROUBLESHOOTING:

Problem	Cause	Solution
Leak between flange and valve body.	Damaged or missing o-ring on face of valve.	Replace face seals.
	Flange mis-aligned with valve.	Loosen flange bolts, align flange and valve, and re-install bolts. Be certain pipe is evenly supported upstream and downstream of valve.
	Over / under / unequally torqued flange bolts.	Loosen all flange bolts. Re-torque flange bolts in alternating sequence. See Table 1 for flange bolt torques.
	Raised face on flange does not align with o-ring seal on face of body.	Raised face on flange is not to ANSI standard. Replace flange with ANSI flange, or use full faced rubber gasket between flange and valve.
Disc does not check / seal.	Damaged or missing o-ring on disc.	Replace disc o-ring.
	Damaged seal surface on body.	Replace valve.
	Debris between disc and seal surface on body.	Clean seal surface. Install a strainer upstream of valve to prevent seal surfaces from becoming dirty and to prevent disc from becoming wedged in an open position.
	Too little back pressure to generate seal.	WCV-Series wafer check valves require between 2 and 3 psi to generate a seal.
	Too little back flow to generate seal.	WCV-Series wafer check valves require minimal back flow to generate a seal. Applications with too little back flow should use a valve with a spring installed to help generate a seal.
	Valve installed in horizontal piping.	Install a spring, or purchase valve with spring.
Disc does not fully open (reduced flow rate).	Over / unequally torque flange bolts.	Loosen all flange bolts. Re-torque flange bolts in alternating sequence. See Table 1 for flange bolt torques.
	Flange mis-aligned to valve.	Loosen flange bolts, align flange and valve, and re-install bolts. Be certain pipe is evenly supported upstream and downstream of valve.
Damaged disc.	Excessive flow rate.	Line velocities must be limited to 8 ft./sec. maximum.
	Solids in process media.	Install a strainer upstream of valve to prevent damage to valve.
	Cavitation in line.	Line velocities must be limited to 8 ft./sec. maximum. Valve should be installed at least 5 pipe diameters from the nearest pump or fitting.
	Disc pulsating.	Install a spring on valve to bias valve to closed position.
Increase distance between valve and pump outlet to allow flow to normalize before reaching valve.		
Valve does not open / No flow through valve.	Valve is installed backwards.	Increase distance between valve and expansion / reducer fitting to at least 5 pipe diameters in length, to allow flow to normalize before reaching valve.
		Verify arrow on valve body is in line with system flow. Correct valve orientation.

5.0 PRODUCT SPECIFICATIONS:

Max. Pressure: 150 psi @ 70°F (see Chart 1 for operating pressures at elevated temperatures)

Max. Temperature: CPVC: 190°F (see Chart 1)
 PVC: 140°F (see Chart 1)

Max. System
 Flow Velocity: 8 ft/s

Flow Capacity, Cv:	2"	93
	2-1/2"	144
	3"	187
	4"	346
	6"	848
	8"	1643
	10"	2249
	12"	3357

WARNING

The maximum recommended fluid velocity through any plastic piping system is eight feet per second (8 ft/s). Higher fluid velocity can create excess water hammer effect, resulting in property damage, personal injury, or even death.

CAUTION

Published operating requirements are based on testing of new valves using clean water at 70°F. Valve performance is affected by many factors including fluid chemistry, viscosity, specific gravity, flow rate, and temperature. These should be considered when sizing Hayward products.

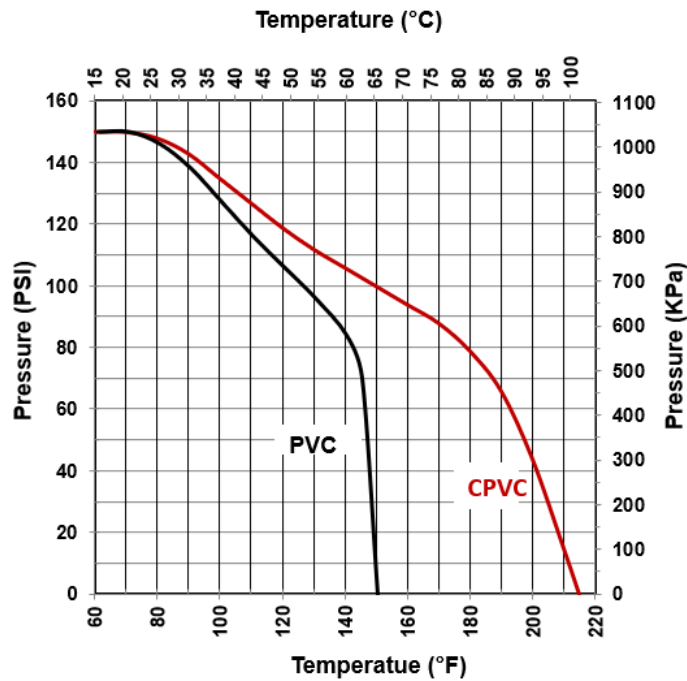

Chart 1: Operating pressures at elevated temperatures

6.0 PARTS LIST:

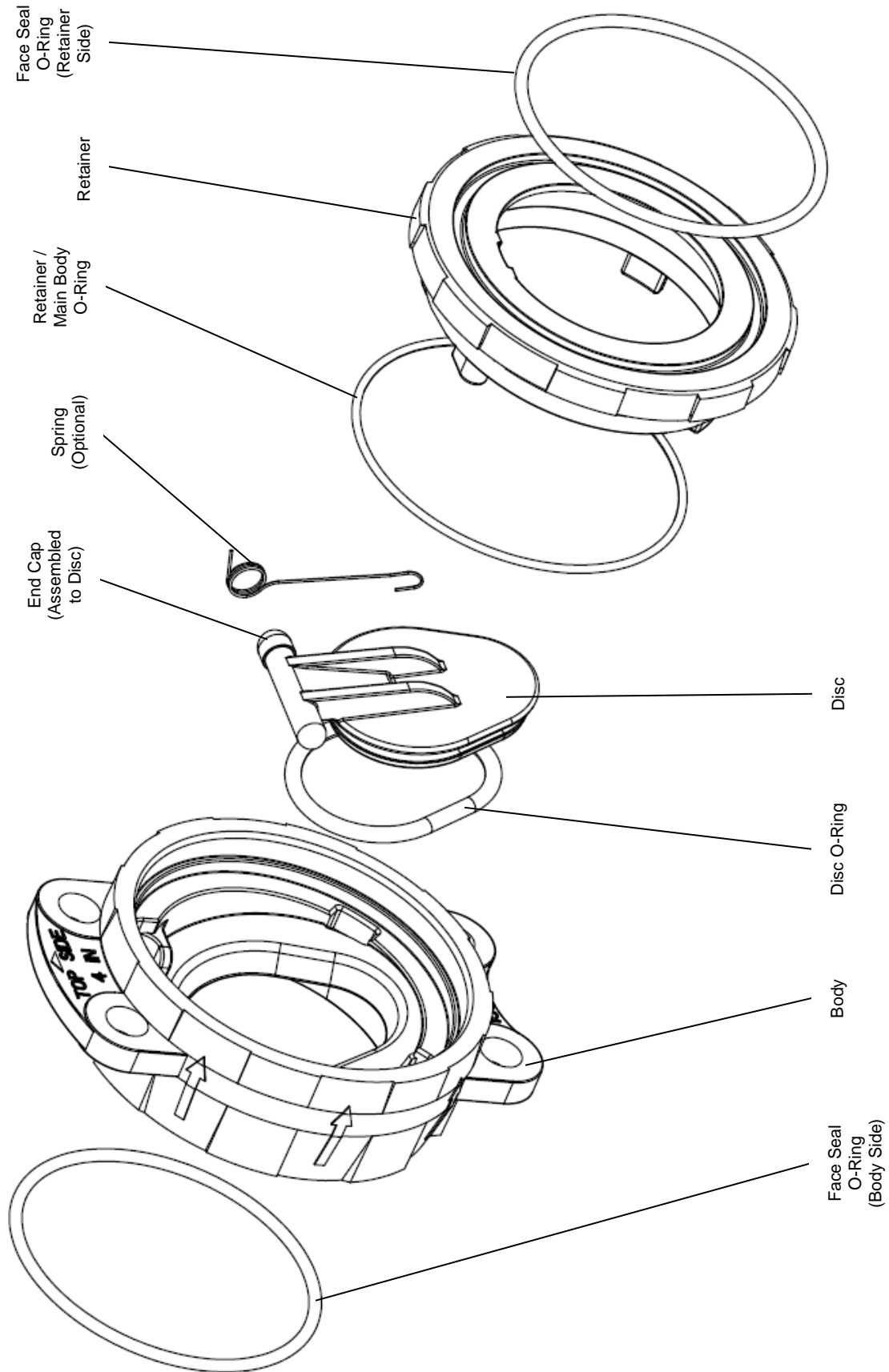

Fig. 3A: Exploded view of WCV-Series Wafer Check Valve, 2" through 8"

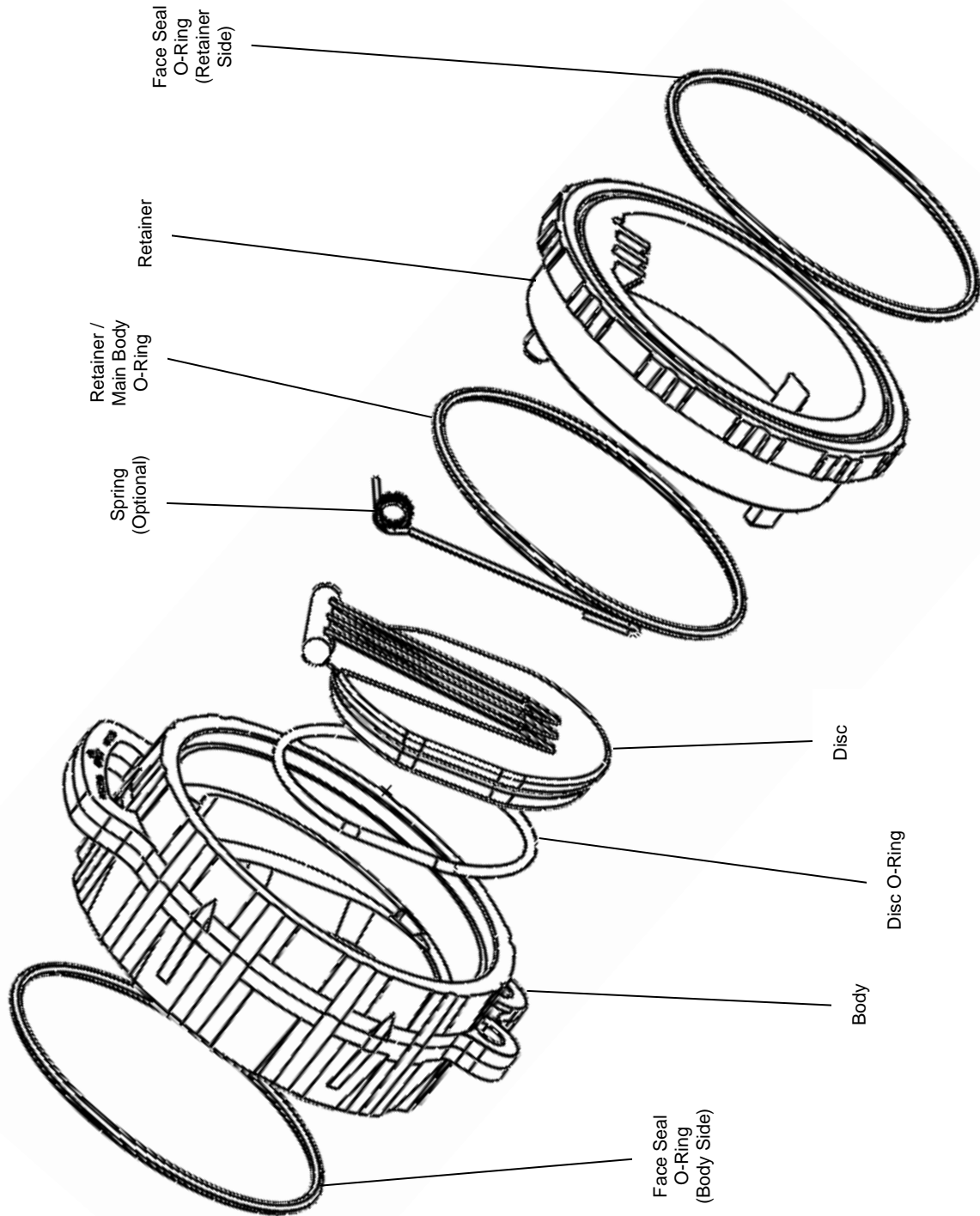

Fig. 3B: Exploded view of WCV-Series Wafer Check Valve, 10" & 12"

7.0 WARRANTY TERMS AND CONDITIONS:

THREE YEAR WARRANTY: All products manufactured by Hayward are warranted against defects in material or workmanship for a period of three years from date of shipment. Our sole obligation under this warranty is to repair or replace, at our option, any product or any part or parts thereof found to be defective. HAYWARD MAKES NO OTHER REPRESENTATION OR WARRANTY, EXPRESS OR IMPLIED, INCLUDING, BUT NOT LIMITED TO, ANY IMPLIED WARRANTY OF MERCHANTABILITY OR FITNESS FOR A PARTICULAR PURPOSE. The warranty set forth above is the only warranty applicable to Hayward products and in no event shall Hayward be liable for any delay, work stoppage, cartage, shipping, loss of use of equipment, loss of time, inconvenience, loss of profits of any direct or indirect incidental resulting from or attributable to a breach of warranty. The remedies under this warranty shall be the only remedies available. OUR MAXIMUM LIABILITY SHALL NOT IN ANY EVENT EXCEED THE CONTRACT PRICE FOR THE PRODUCT.

Authorised Distributor of Hayward Flow Control, a Division of Hayward Industries, Inc

Hayward Flow Control has been a leading manufacturer of industrial thermoplastic valves and process control products for more than 60 years. In fact, Hayward was one of the originators of the first thermoplastic ball valves. Since then, we have remained committed to producing the highest quality products while providing outstanding service.

Liquid Filters and Strainers



Bag Filter vessel

- GFPP
- PVC
- CPVC



Simplex Strainers

- PVC
- CPVC
- GFPP
- PVDF
- Eastar® (Clear)



Y Strainers

- PVC
- CPVC
- Clear PVC
- PVDF



Duplex Strainers

- PVC
- CPVC
- GFPP
- Eastar® (Clear)

Valves and Flow Control



Ball Valves

- PVC
- CPVC
- GFPP
- PVDF



Butterfly Valves

- PVC
- CPVC
- GFPP
- PP
- PVDF



Check Valves

- Ball Check Valves
- Y-Check Valves
- Wafer Check Valves
- Swing Check Valves



Actuation

- Electric
- Pneumatic



Pressure & Chemfeed

- Injection Quills
- Back Pressure
- Pressure Relief
- Diaphragm Valves
- Needle Valves
- Angle Globe Valves



Solenoid Valves

- PVC
- CPVC
- PVDF



Australia

Monarch Asia Pacific Pty Ltd
Unit 3
8 Bult Drive
Brendale, QLD 4500

Phone : +61 (0) 7 3889 9949

www.monarcindustrial.com.au



Thailand

PSF Equipment (Thailand) Co Ltd
11 Soi Suanphak 42
Suanphak Road, Chimphi
Talingchan, Bangkok 10170

Phone : +66 (0) 2 882 5512
Fax No: +66 (0) 2 424 3725

www.psfthailand.com