

Option 1- Standard Flange

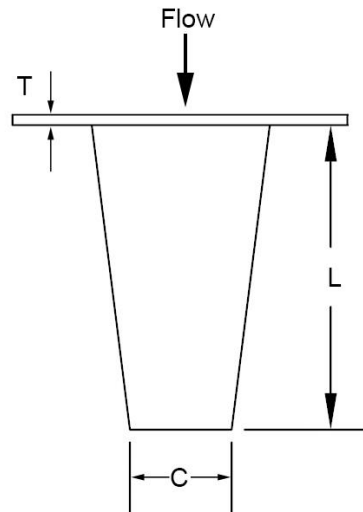

Option 2 – Flange with Hole Pattern

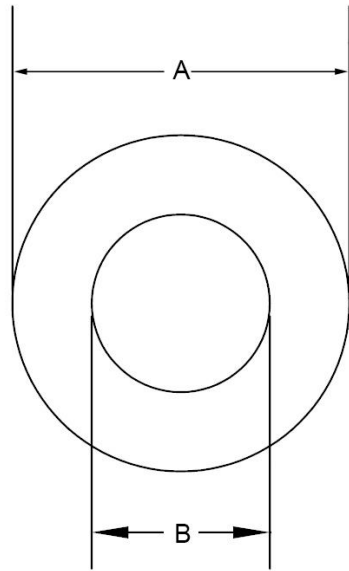
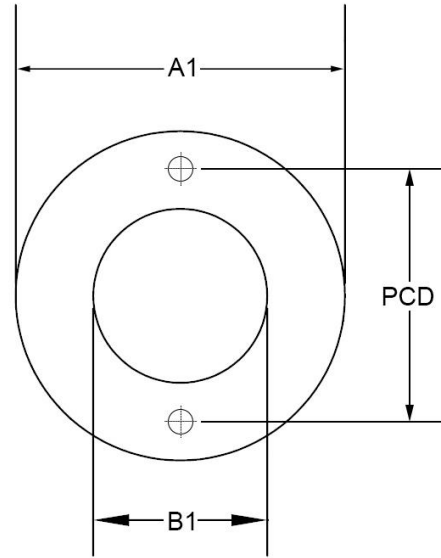

Notes

Option 1- Standard Flange

A		mm
B		mm

Option 2 – Flange with Hole Pattern

A1		mm
B1		mm
P.C.D.		mm
Hole Dia.		mm
No. of holes		mm

Basket Dimensions (mm)

T		mm
L		mm
C		mm
(T) Standard thickness is 3mm		

Material

304 S/S		316 S/S	
---------	--	---------	--

Removal Size

--

Please complete, save as a PDF and return for quoting.

	Doc No. WD0010	Title:	Truncated Cone Strainer Basket
Date:		Name:	
Monarch Ref No.		Company:	
Customer Ref No.		Email:	
NOT TO SCALE		Phone:	

Return to:

sales@monarchindustrial.com.au



www.monarchindustrial.com.au