

Poly-Lite Bag Filter/Strainer
Polypropylene - Light Duty

The Poly-Lite Filter offers an economical and user friendly alternative to many liquid filtration applications with favourable operating cost benefits.

PL50 & PL75 housings are constructed from high impact polypropylene to be compatible with a wide range of fluids and its ergonomic screw down lid is designed for simple hand operation allowing for a quick filter changeover.

Bags Required

PL50 - 1 x 01 size filter bag (7" dia x 17" long)

PL75 - 1 x 02 size filter bag (7" dia x 32" long)

Strainer Baskets

Various Perforation & Mesh Sizes, Please contact our office for sizing options

Connections - 2" BSP Thread/Socket

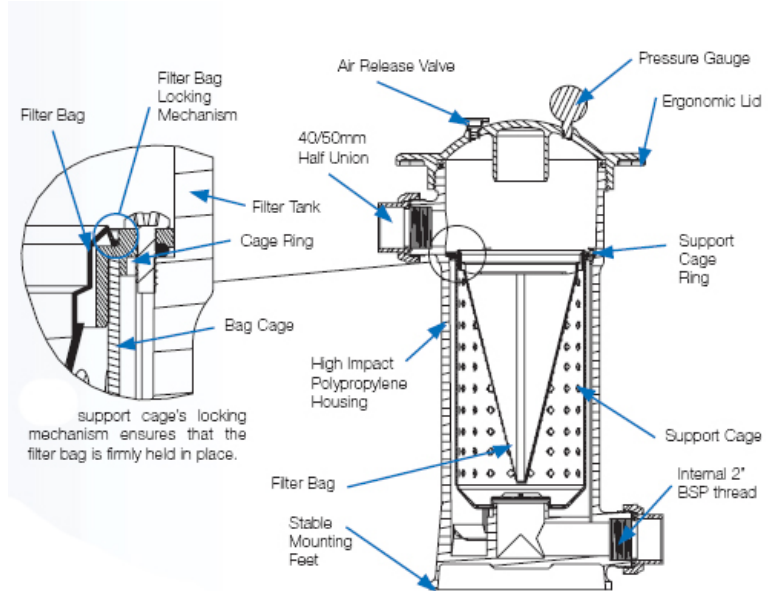
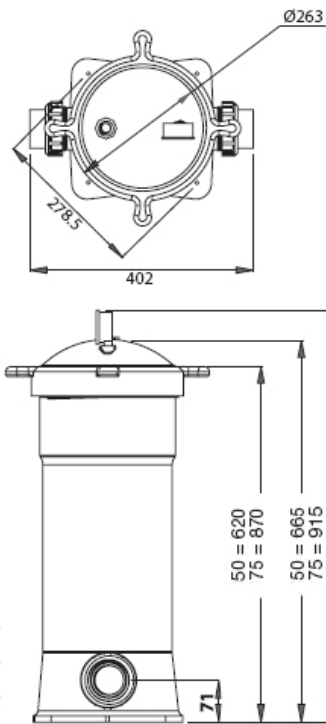

Specifications	PL50		PL75	
Max Flow Rate	190 lpm	50 gpm	270 lpm	70 gpm
Required clearance for servicing	530 mm	20.9"	770 mm	30.3"
Max pressure	600 KpA	87 psi	600kPa	87 psi
Max temperature	40°C	100°F	40°C	100°F

Accessories and Options



Bag Fixing Ring

The standard Poly-Lite has tabs to hold the filter bag in position. The Bag Fixing Ring replaces the tabs and provides a quicker, more convenient and more positive method of bag fixing.



Strainer Basket

The Stainless Steel Strainer Basket replaces the Filter Bag.

Many perforation sizes and mesh linings are available.



Pre-Strainer

The Stainless Steel Basket fits inside the filter bag and acts as a pre-strainer, removing larger particles. The pre-strainers can also be used to protect the bag from sharp objects in certain applications. Requires a Bag Fixing Ring to retain the Bag/Basket combination.

Many perforation sizes and mesh linings are available.